



# CLASSICO CLASSIC

La gamma classica Salice Paolo copre tutti i principali stili ed epoche, con disegni originali fatti realizzare da artigiani cresciuti nella prestigiosa Scuola di Arti e Mestieri di Cantù. Le finiture disponibili, la possibilità di personalizzazione e il gran numero di accessori consentono di arredare completamente grandi abitazioni private, ville e resort di prestigio. Pur guardando al passato, la gamma classica Salice Paolo si arricchisce continuamente di nuove finiture, modelli, aggiornamenti, dotazioni tecniche, versioni per tutti i tipi di serrature da interno ed esterno.

*The classic Salice Paolo range covers all the main periods and styles, with its original designs made by the artisans grown in the prestigious School of Arts and Crafts in Cantù. The available finishings, the possibilities for customization and the large number of accessories allow you to fully furnish large private homes, as well as villas and luxury resorts. While looking at the past, the classic range of Salice Paolo is continuously enriched by new finishes, patterns, updates, technical equipment, and varieties for all types of locks from inside and outside.*





# Nottolini

Turnpiece



### 5200 KINGSTONE



### 5201 POLO

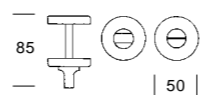

### 5202 OSLO

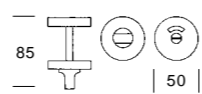

### 5203 ORIENTE

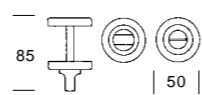

### 5204 GIAVA

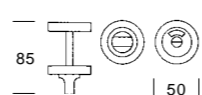

### 5205 GELA

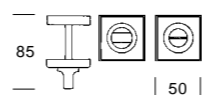



# AVIGNONE

Stile: Impero



Stile: Neoclassico



# BORDEAUX



3014/S

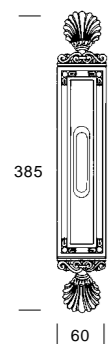

4315/3014

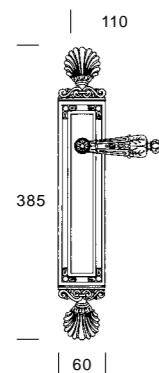

3115/3015

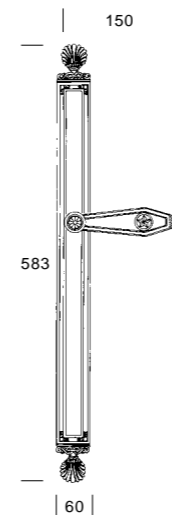



# ATENE

Stile: Tardo '700



Stile: Impero



# NANCY



3116/3019

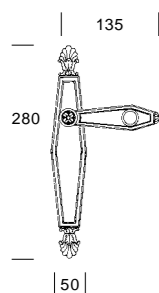

3016/S



4315/3016

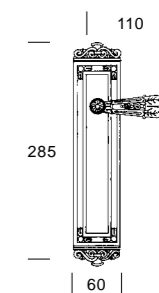



# SHARJAH

Stile: Arabesco



Stile: Louis XV



# TOURS



3020

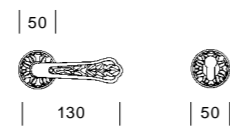

3021

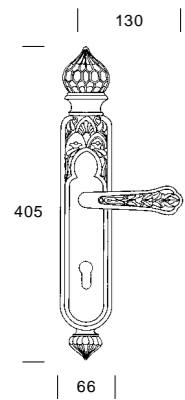

3026

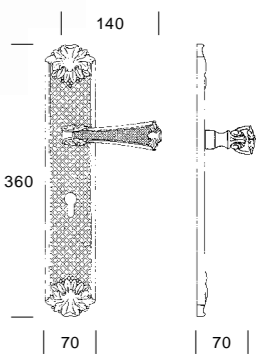



Stile: Luigi Filippo - fine 1700



3031

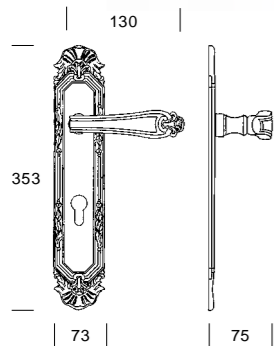

3032



3031/S

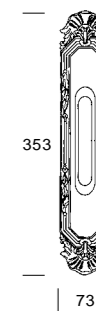



Stile: '700 Spagnolo



LUCCA



3040 



3041 







REIMS

Stile: Louis XV



REIMS



3046



3045



3047

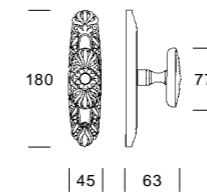

3047/4340







# MONTPELLIER

Stile: Chippendale



Stile: Influsso Orientale



# LUXOR



3051/S

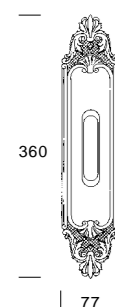

3051

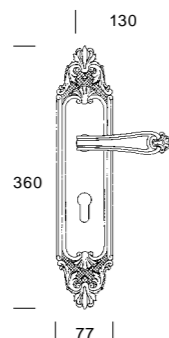

3056

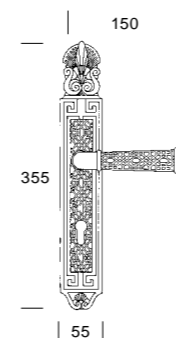

3055

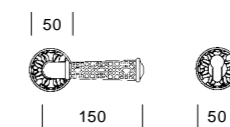



# GINEVRA

Stile: Luigi Filippo - fine 1700



3075



| 50 |



| 116 |



| 50 |



# GINEVRA



3076



| 116 |



| 255 |

| 53 |



# GINEVRA



# KIEV



3078/S WC

3078/S CF

3078/S

3076/S

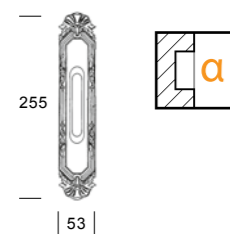

3077/S

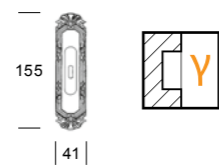

3077/S

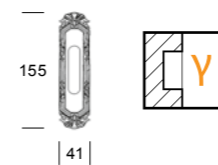



3091 

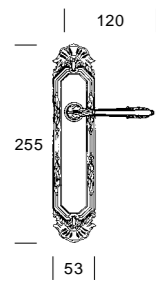

3090 

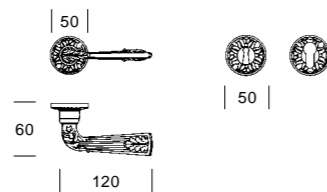



Stile: Luigi Filippo - fine 1700



**KING**



**3096** 

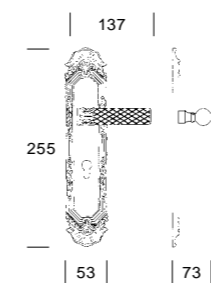

**3095** 

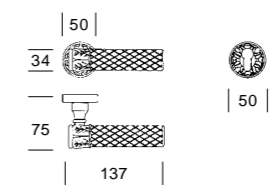



# VERSAILLES

Stile: Louis XVI



3100/3001

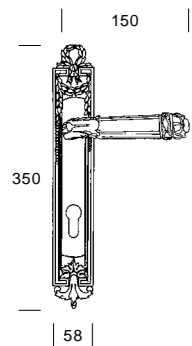

3100/3085

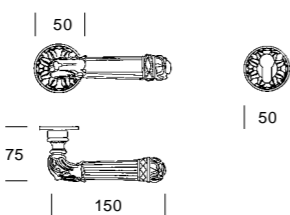

# VERSAILLES



3001/S







Stile: Metà '700



# PAESTUM



3118 

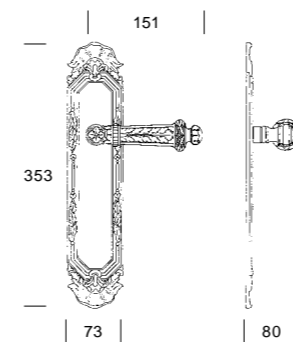

3117 

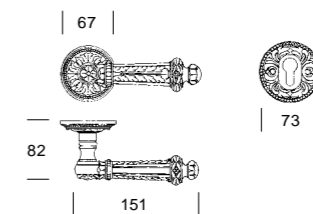



# DAKAR

Stile: Riesener



# DAKAR



3261 

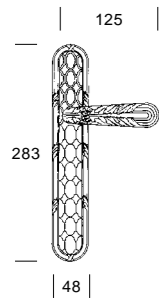

3260 



3262

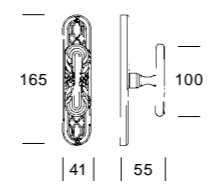

3262/3085

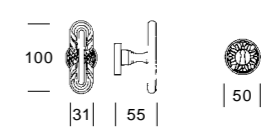



# DOHA

Stile: Impero



# DOHA



3302 



3300 

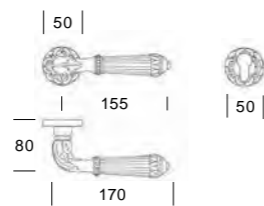

3301 

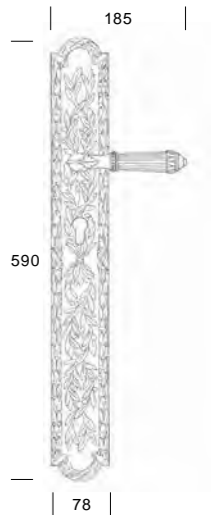



Stile: Impero



# NAXOS



3307 



3305 

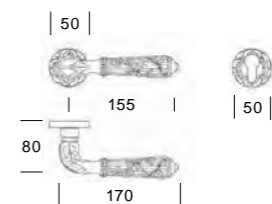



# NAXOS



Stile: Floreale



# BAKU



3306 

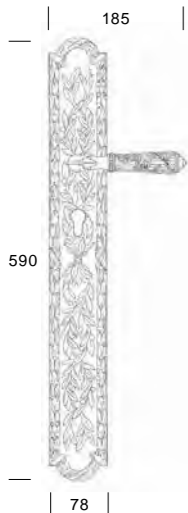

3311 

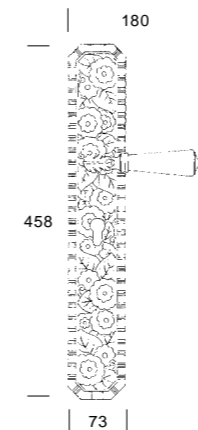

3310 

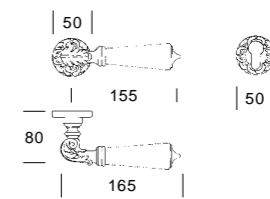

CAPUA

Stile: Metà 700



Stile: Louis XVI

LILLE

Nuova dimensione  
New smaller size

Nuova dimensione  
New smaller size

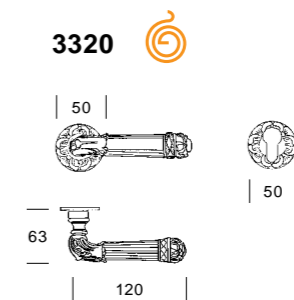
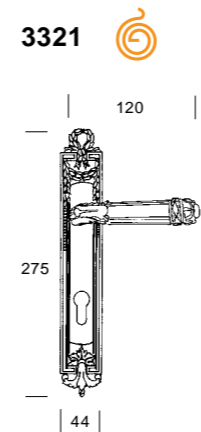
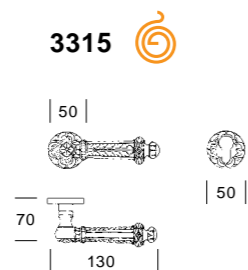
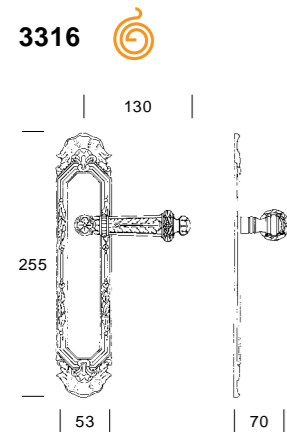





# FRESIA

Riccardo Arbizzoni

Stile: Fine 800



# FRESIA



3256

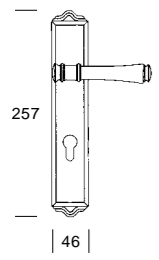

### Finiture Finishes

DOR 24K

ETR

OL

D

3255

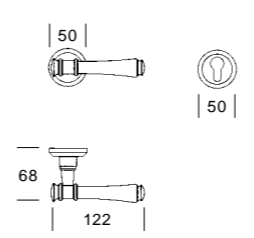

3258/BIS

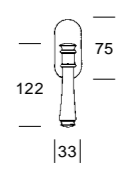

3257

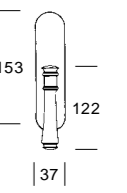





# CASSIA

Riccardo Arbizzoni

Stile: Fine 800



# CASSIA



### Finiture Finishes

DOR 24K

ETR

OL

D

3251

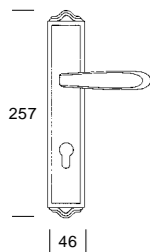

3250

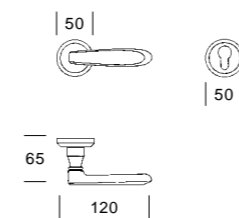

3253/BIS

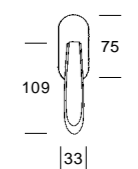

3253

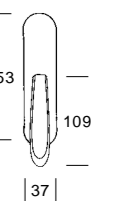



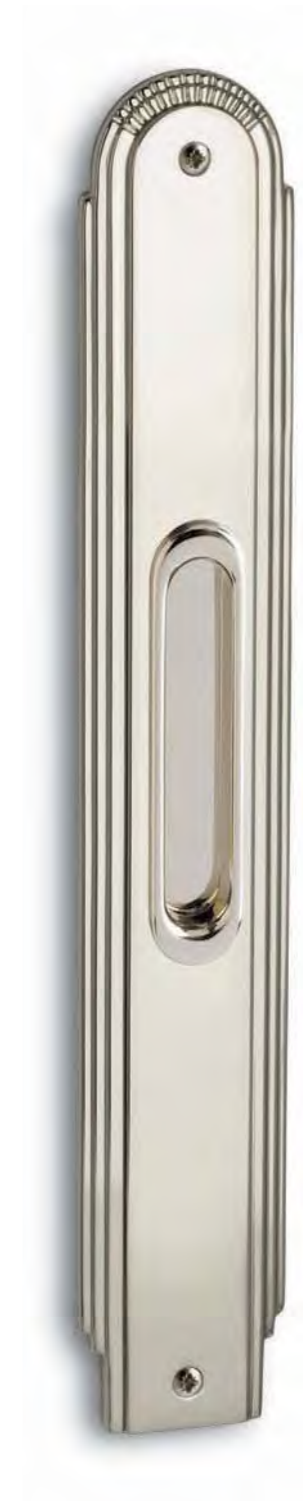

**3336** 

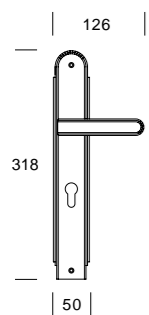

**3335** 

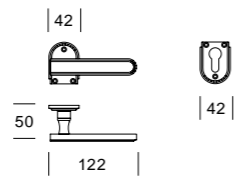

**3336/S**

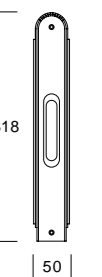



# MEDINA

Stile: Art Déco



# MEDINA



4206

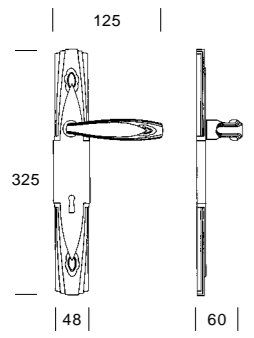

4205



4206/S

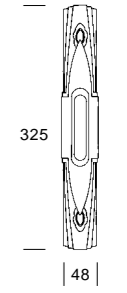





# BRUGES

Stile: Louis XV



# BRUGES



3331

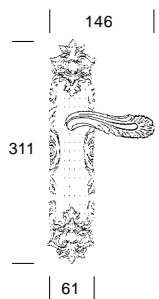

3330

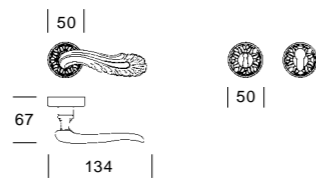

3331/S

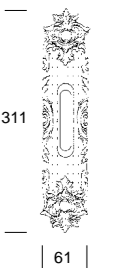



Stile: Barocco



# LISBONA



4251

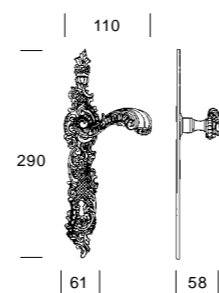

4250

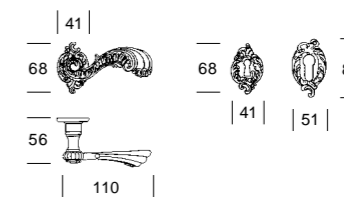

# LISBONA



4252

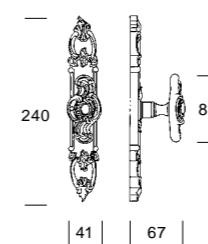

4252/4250

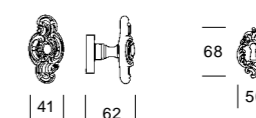





# MASQUAT

Stile: Regency



# MASQUAT



4256

4255 

4256/S

4258

4258/4255

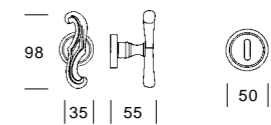
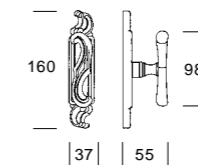
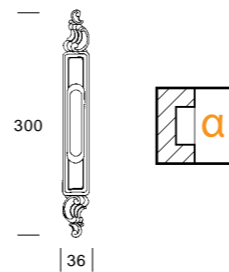
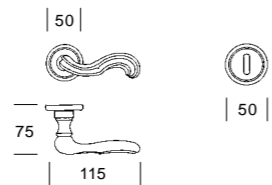
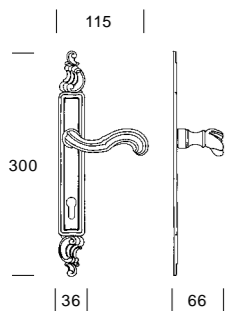



# SAMARRA

Stile: Barocco Piemontese



# SAMARRA



4271

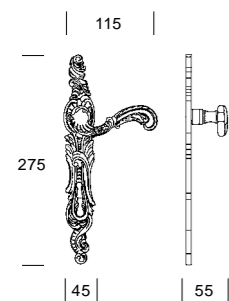

4270

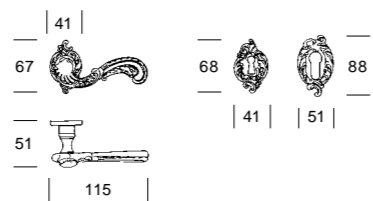

4273

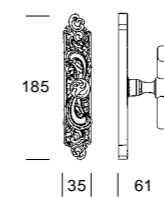

4273/4270

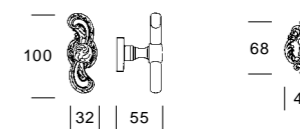





# DAMASCO

Stile: Tardo '600



# DAMASCO



4286

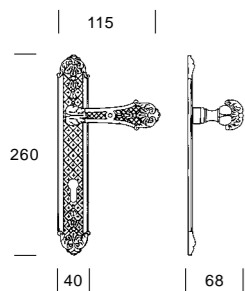

4285

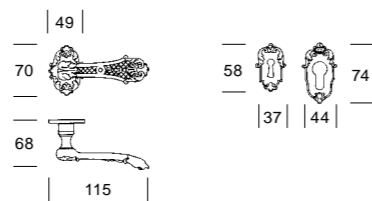

4286/S

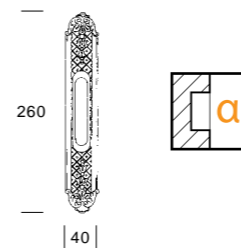

4287

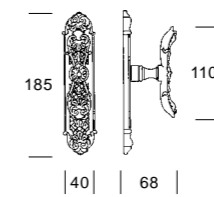

4287/4285

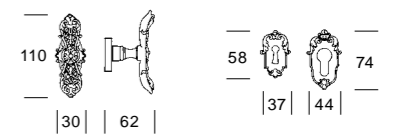



# VIENNA

Stile: Louis XVI



4291

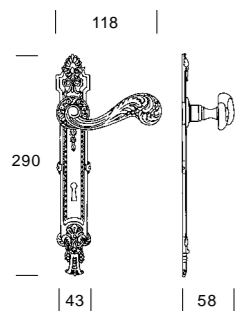

4290

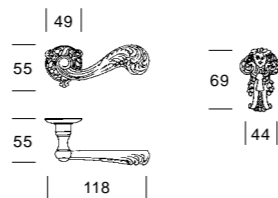

4293

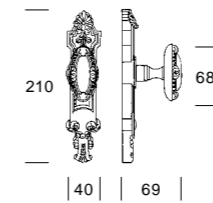

# VIENNA



4293/4290

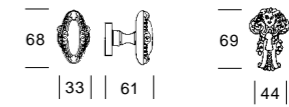



# ORLEANS

Stile: Louis XVI



# ORLEANS



4296



4295

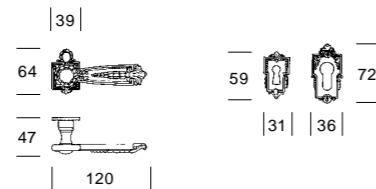
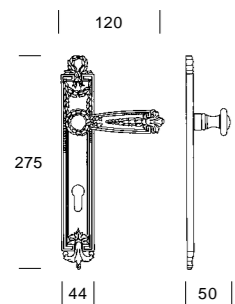

4296/S

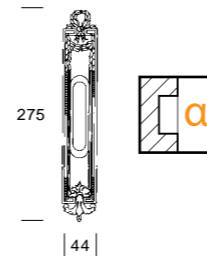

4297/S

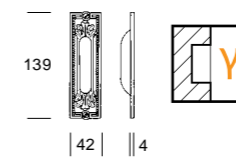

4297

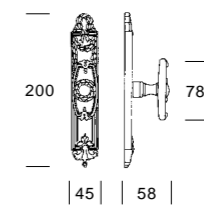

4297/4295

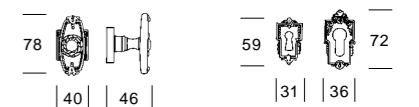



# ORLEANS

Stile: Louis XVI



4297



**4299/D**

Finale  
Final piece

**4299/B**

Cavallotto  
Plate for external bars

**4299/A**

**4297/4299A**

Pomolo con placca per aste esterne  
Knob with plate for external bars

**4299/C**

Cavallotto  
Plate for external bars

**4299/D**

Finale  
Final piece

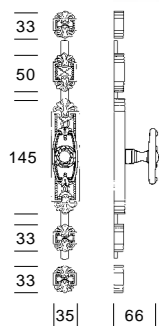



Stile: Louis XVI



# LIMOGES



4297



**4199/D**  
Finale  
*Final piece*

**4199/C**  
Cavallotto  
*Plate for external bars*

**4199/A**

**4297/4199A**  
Pomolo con placca per aste esterne  
*Knob with plate for external bars*

**4199/B**  
Cavallotto  
*Plate for external bars*

**4199/D**  
Finale  
*Final piece*







4295/3006A

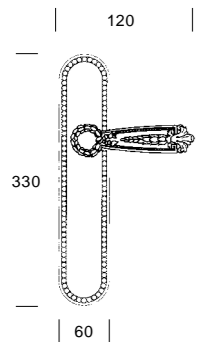

4295/3006B

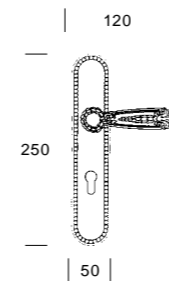

4295/3085

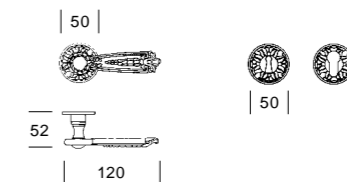



# BEIRUT

Stile: Neoclassico



4301

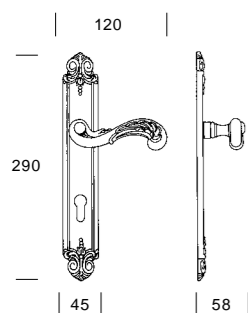

4300

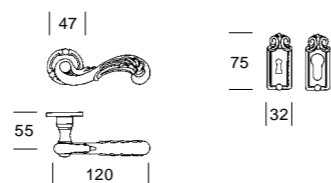

4301/S

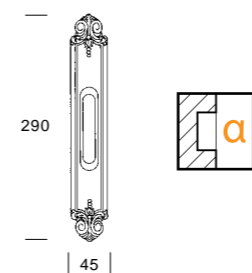

4302

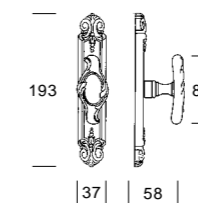

4302/4300

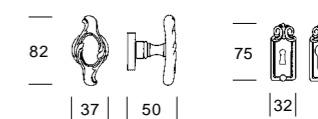

# BEIRUT



# IL CAIRO

Stile: Secolo XIV



4306

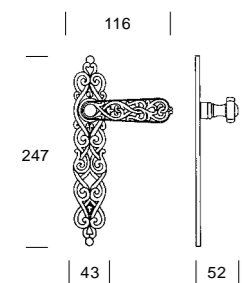

4305

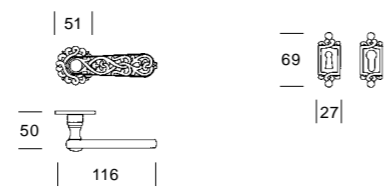

4307

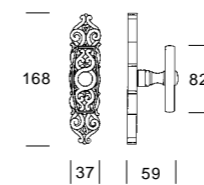

4307/4305

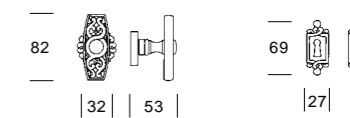

# IL CAIRO





# DELHI

Stile: Metà XVII secolo



# DELHI



4311

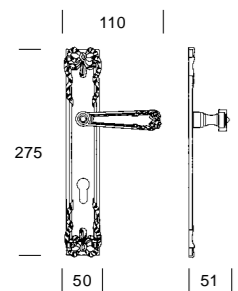

4310

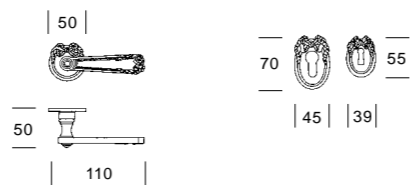

4312

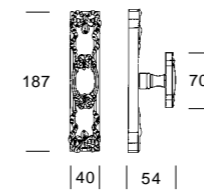

4312/4310

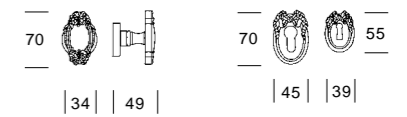



# RIYADH

Stile: Arabesco



4311/2 

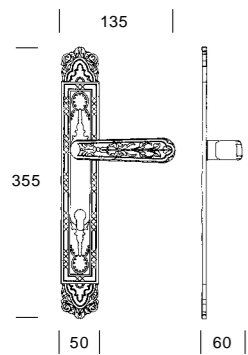



4316

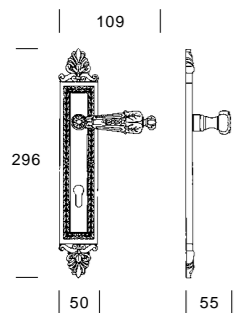

4315

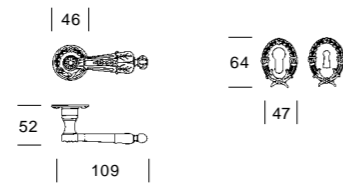

4316/S

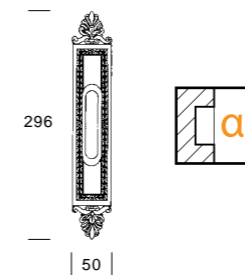

4317

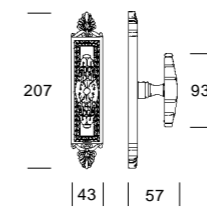

4315/C

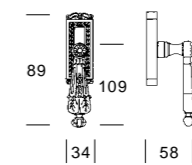

4317/4315

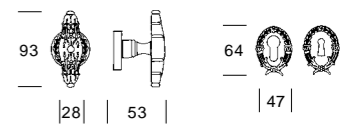





# SHANGHAI

Stile: Tardo '700



4331

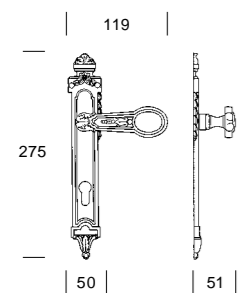

4330

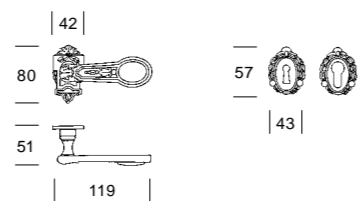

4332

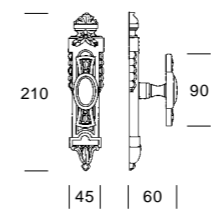

4332/4330

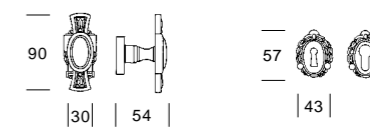

# SHANGHAI





# JAKARTA

Stile: Louis XV



4336

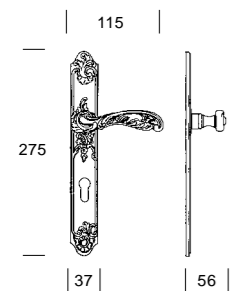

4335

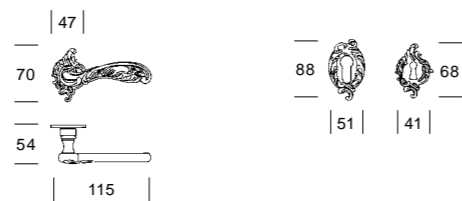

4338

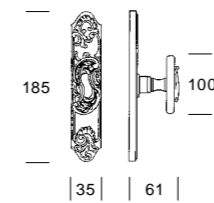

4338/4335

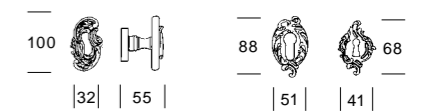

# JAKARTA



Stile: Impero



# URBINO



4341 

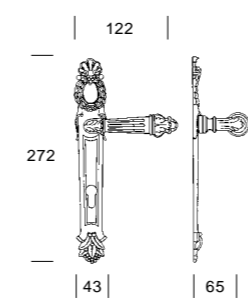

4340

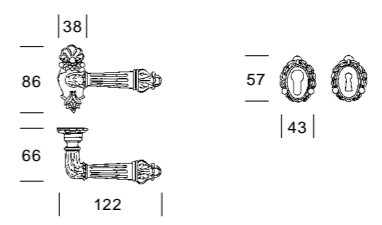

# URBINO



4342

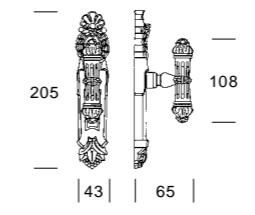

4342/4340

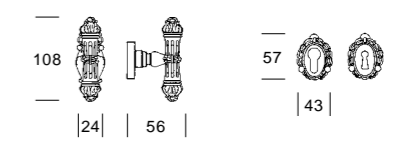

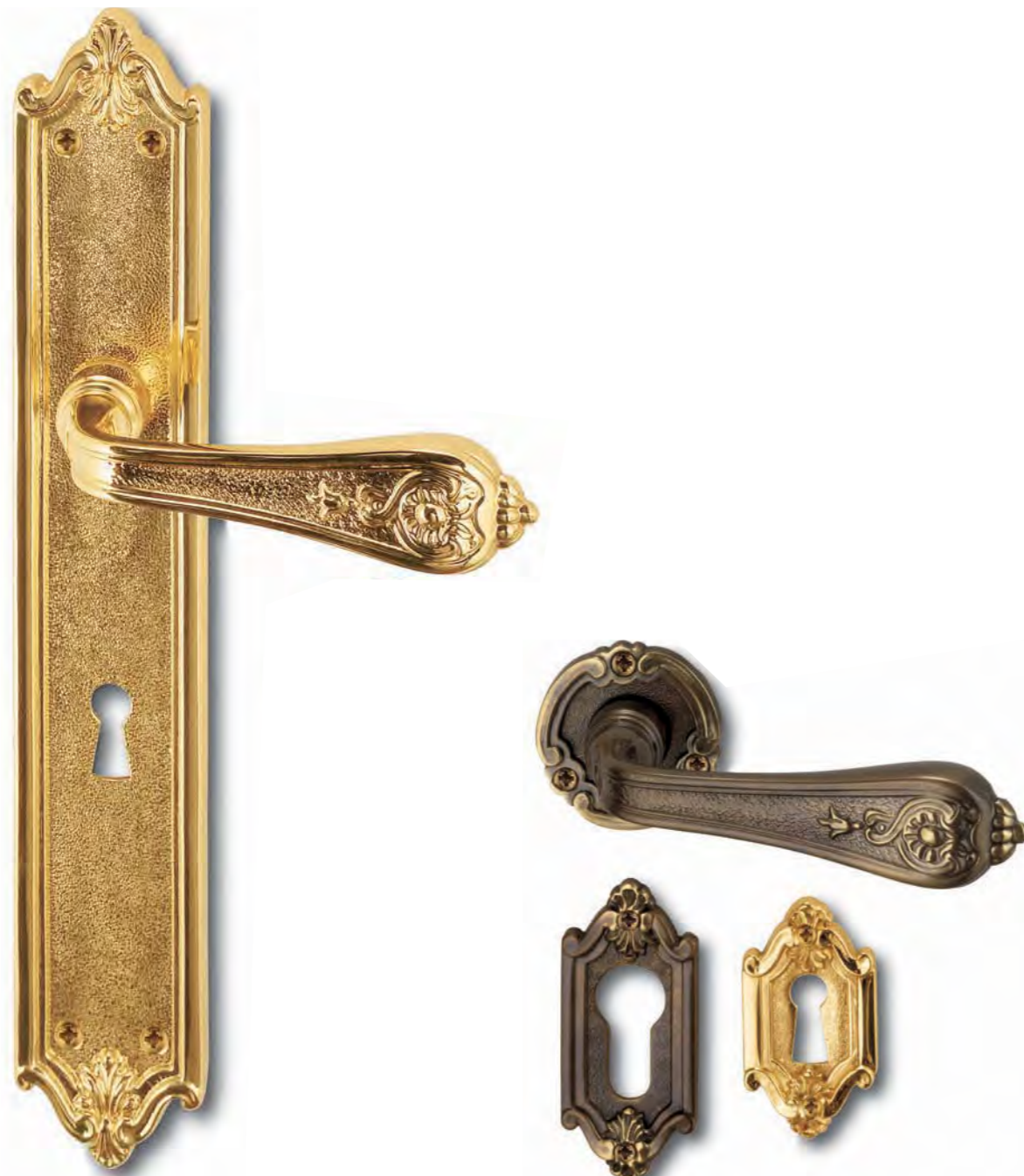

4346

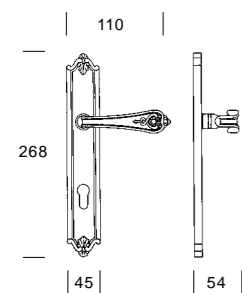

4345

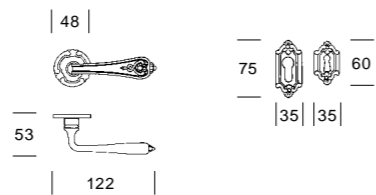

4346/S

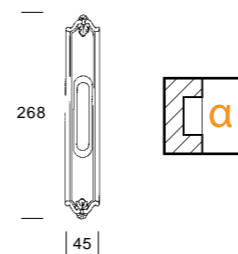

4347

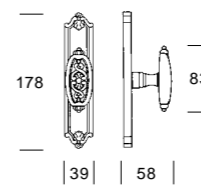

4345/C

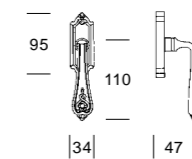

4347/4345

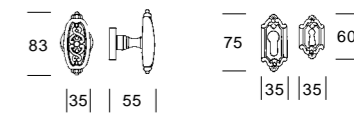



# HANNOVER

Stile: Inglese



# HANNOVER



4351

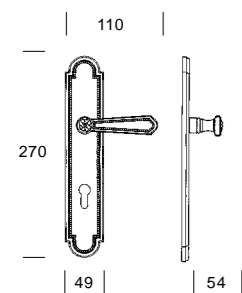

4350

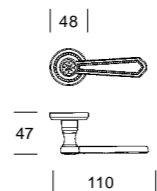

4351/S

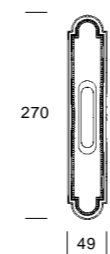

4352

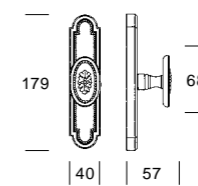

4352/4350

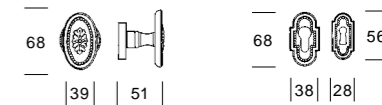



# BERLINO

Stile: 700 tedesco



# BERLINO



4391

4390

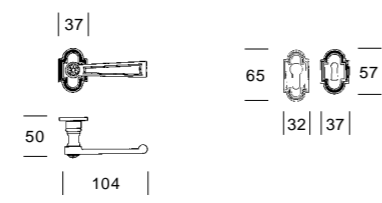
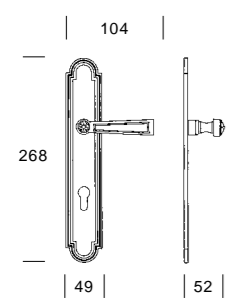

4391/S

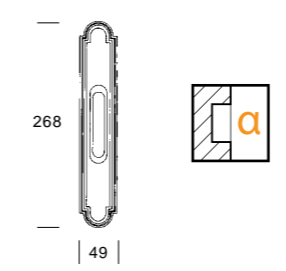

4392

4392/4390

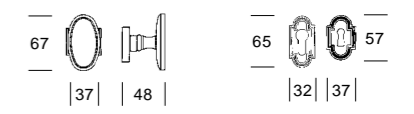
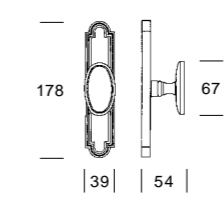



# MADRID

Stile: Vittoriano



# MADRID



4416

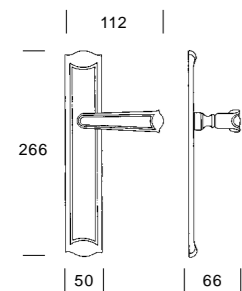

4415

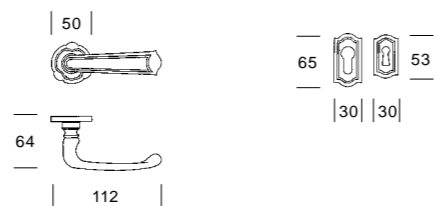

4416/S

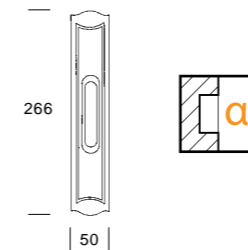

4417

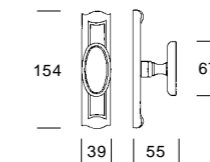

4417/4415

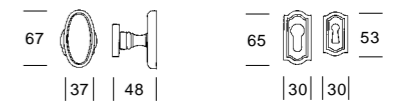



# MANIGLIONI *DOORPULL*





Stile: Coloniale



Stile: Coloniale



4326

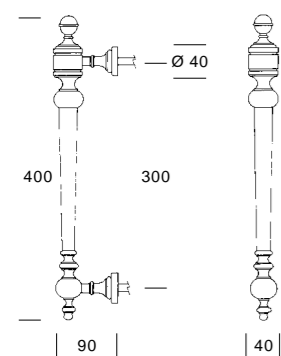

3033

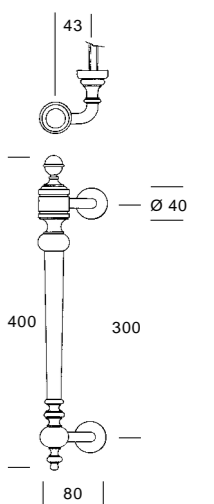



Stile: Fine '800



# SNAKE



3035

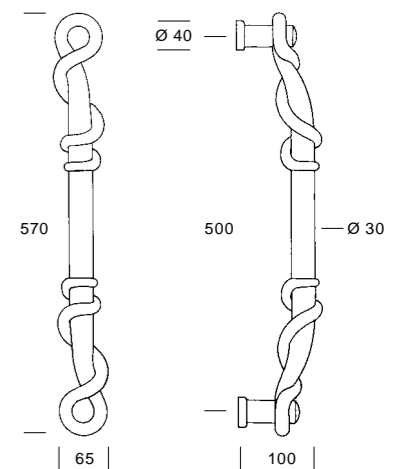



# BOMBAY

Stile: Chippendale



Stile: Chippendale



# KARACHI



3036

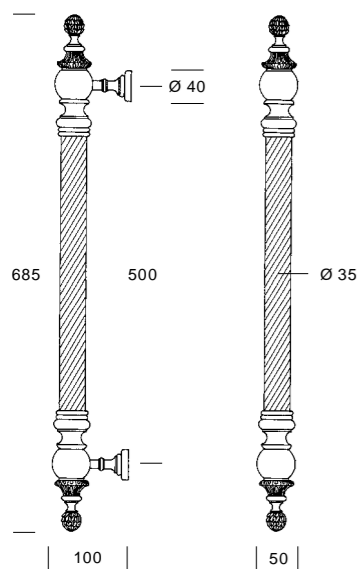

3070

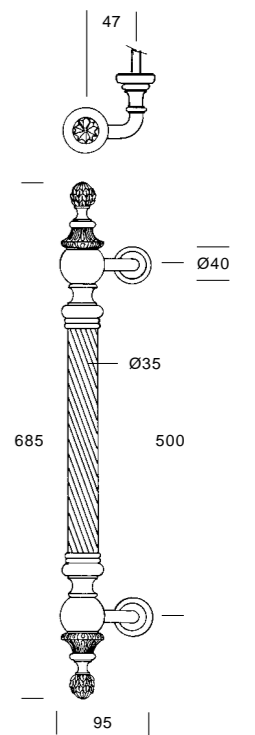



# ISTAMBUL

Stile: Chippendale



Stile: Chippendale



# ANKARA



4328

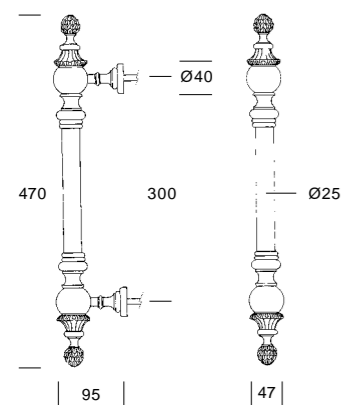

3034

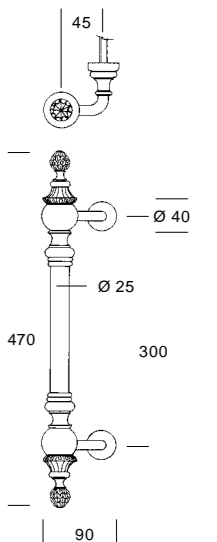



# MADRAS

Stile: Chippendale



Stile: Louis XV



# GULLIVER



3067

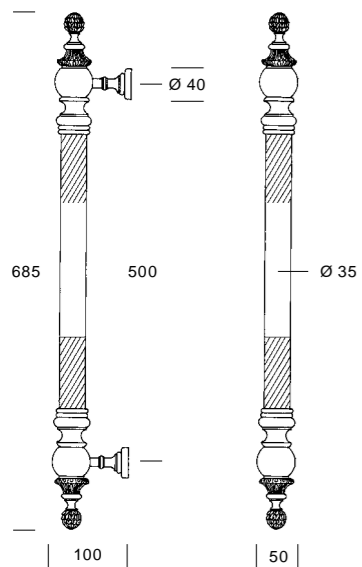

3039/A



3039/B

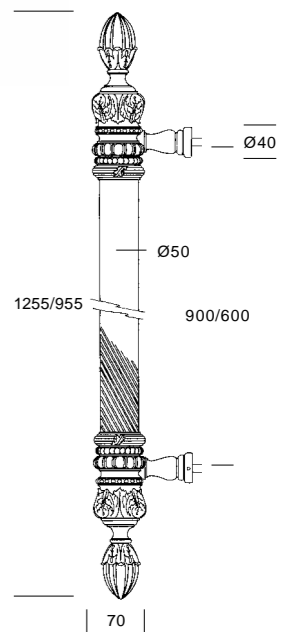



Stile: Romanico



LION



3037

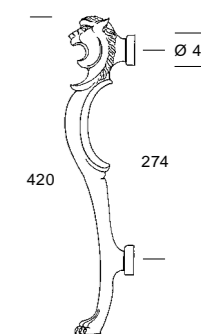



Stile: Fiorentino



KING



3038

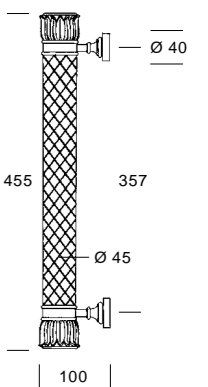

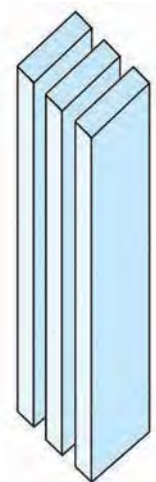

La modalità per ottenere un cristallo cilindrico del diametro di 45 mm con caratteristiche di ottima trasparenza consiste nell'assemblare 3 lastre del tipo "extra chiaro" con speciali colle e trattamenti termici.

*The way to get a cylindrical crystal of the diameter of 45 mm with characteristics of good transparency consists of assembling 3 plates of the type "extra clear" with special neck and thermal treatments.*

Tale pezzo viene poi rettificato con un macchinario unico al mondo che ne lavora la superficie.

*Such piece is corrected then with a worldwide unique machinery that works the surface of it.*

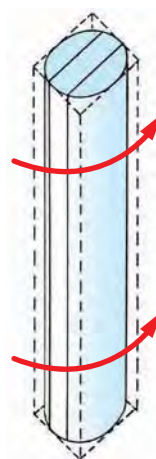

La lucidatura e molatura eseguite a mano da esperti artigiani conferiscono unicità al prodotto.

*The polish and machining performed by hand by expert artisans confer oneness to the product.*

Pertanto, eventuali leggere imperfezioni non sono da ritenersi difetti, ma parte integrante di una lavorazione eseguita manualmente nella maggior parte dei processi di lavorazione.

*So, possible little imperfections are not to consider defects but integral part of the workmanship manually performed in the greatest part of the process of manufacture.*



Stile: Fiorentino



PRINCE



3099

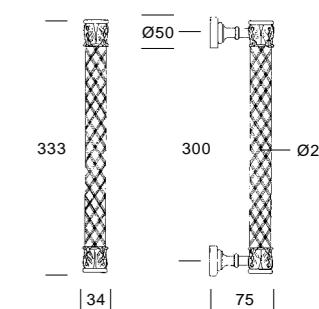





# BOULOGNE

Stile: Impero



Stile: Impero



# DESSAN



3060

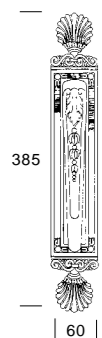

3061



  
**ALAIS**

Stile: Arabesco



Stile: Luigi Filippo - fine 1700

  
**MILSE**



3062



405

| 65 |

3063

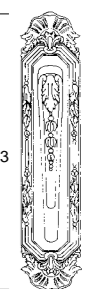

353

| 73 |

NEKLA

Stile: Chippendale



Stile: Louis XV

SEOUL



3064



360

| 77 |

3065

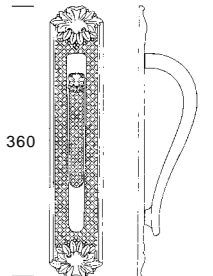

360

| 70 | | 80 |

BYBLOS

Stile: Neoclassico



Stile: Tardo '700



SPARTA



3066

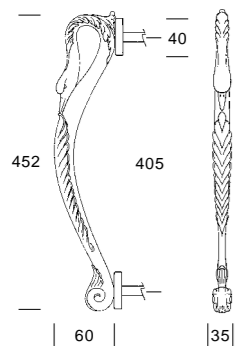

3071

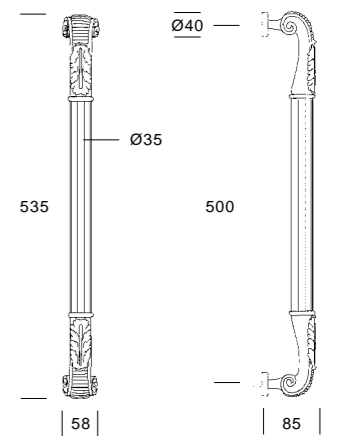



# RHODUS

Stile: Tardo '700



Stile: Tardo '700



# CORINTHUS



3068

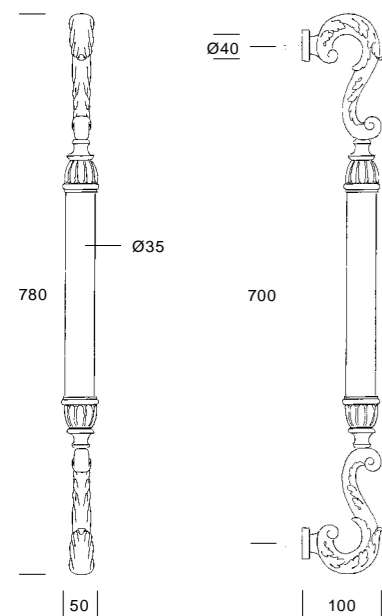

3069

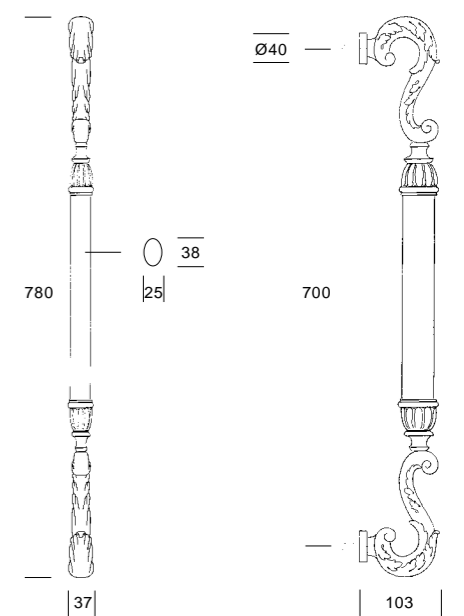





# MATERA

Stile: Neoclassico



# MATERA



4322

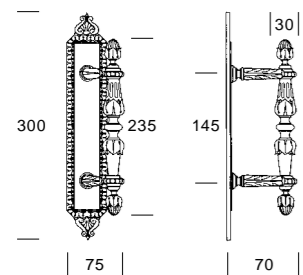

4323

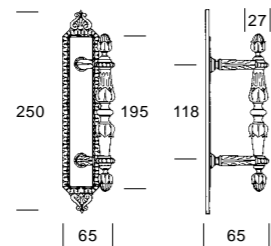

4324

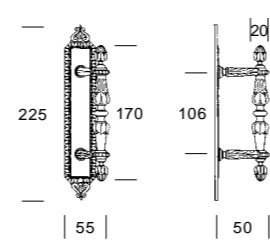

4322/S

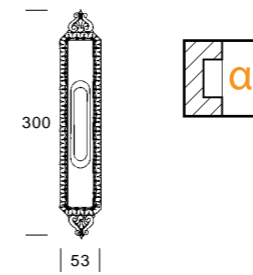

4323/S

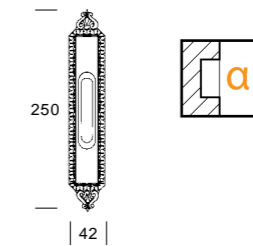

4324/S

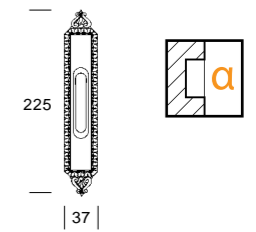



# MANILA

Stile: Metà '700



Stile: Luigi Filippo - fine 1700



# MEDA



4325

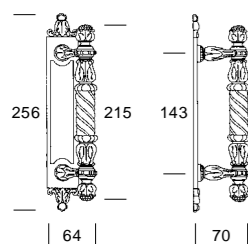

4325/S

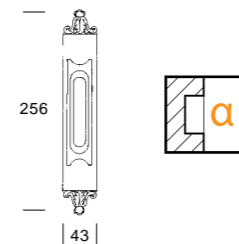

3080/B

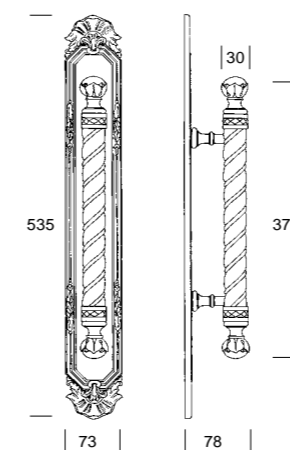

3081/B

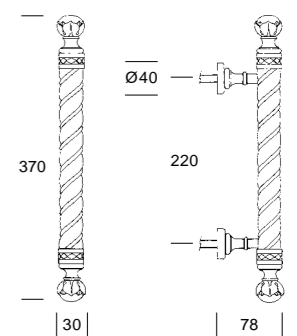





# PARIGI

Stile: Louis XVI



LH

RH

4327



296

| 90 |



PER DITA FIGLI DI PALICE -

\* *S. Maria*

SEZIONE

SEZIONE

MOD (A)

MOD (B)

